

# Lordstown Motors' Endurance: EV Pickup for Today's Fleet & Commercial Needs



# Automotive Technology is in Revolution with EVs – Similar to the Horse-Drawn Carriage / Automobile transition earlier this Century



**LMC is leveraging a factory of the past to build the vehicles of the future.**



**Lordstown Motors has innovated at historic speed from concept to hardware.**



**LMC's In-Wheel Hub Motor**

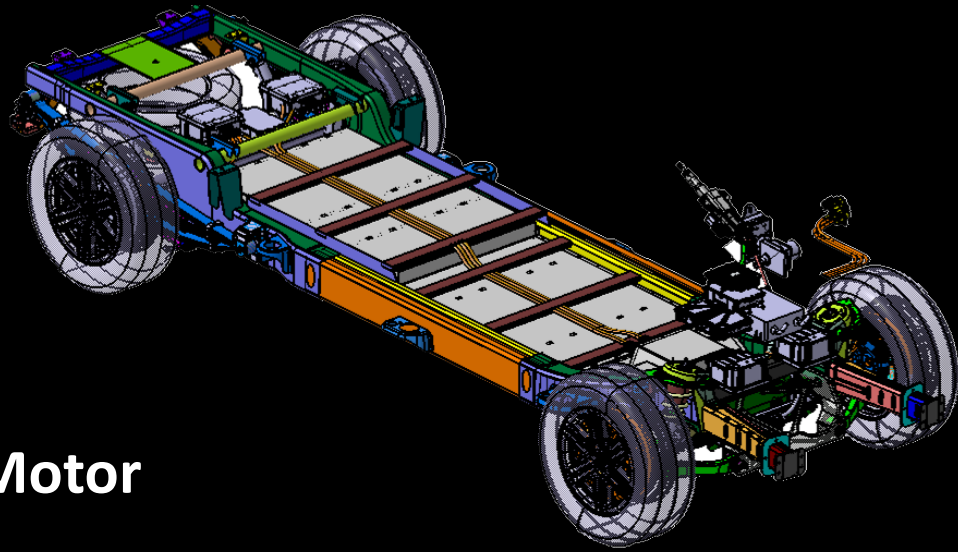

**LMC's Skateboard**



**LMC Endurance Beta**

**LMC's Endurance has met FMVSS crash requirements during Beta crash series.**

**Side-Pole Development Crash Test – FMVSS 214P**

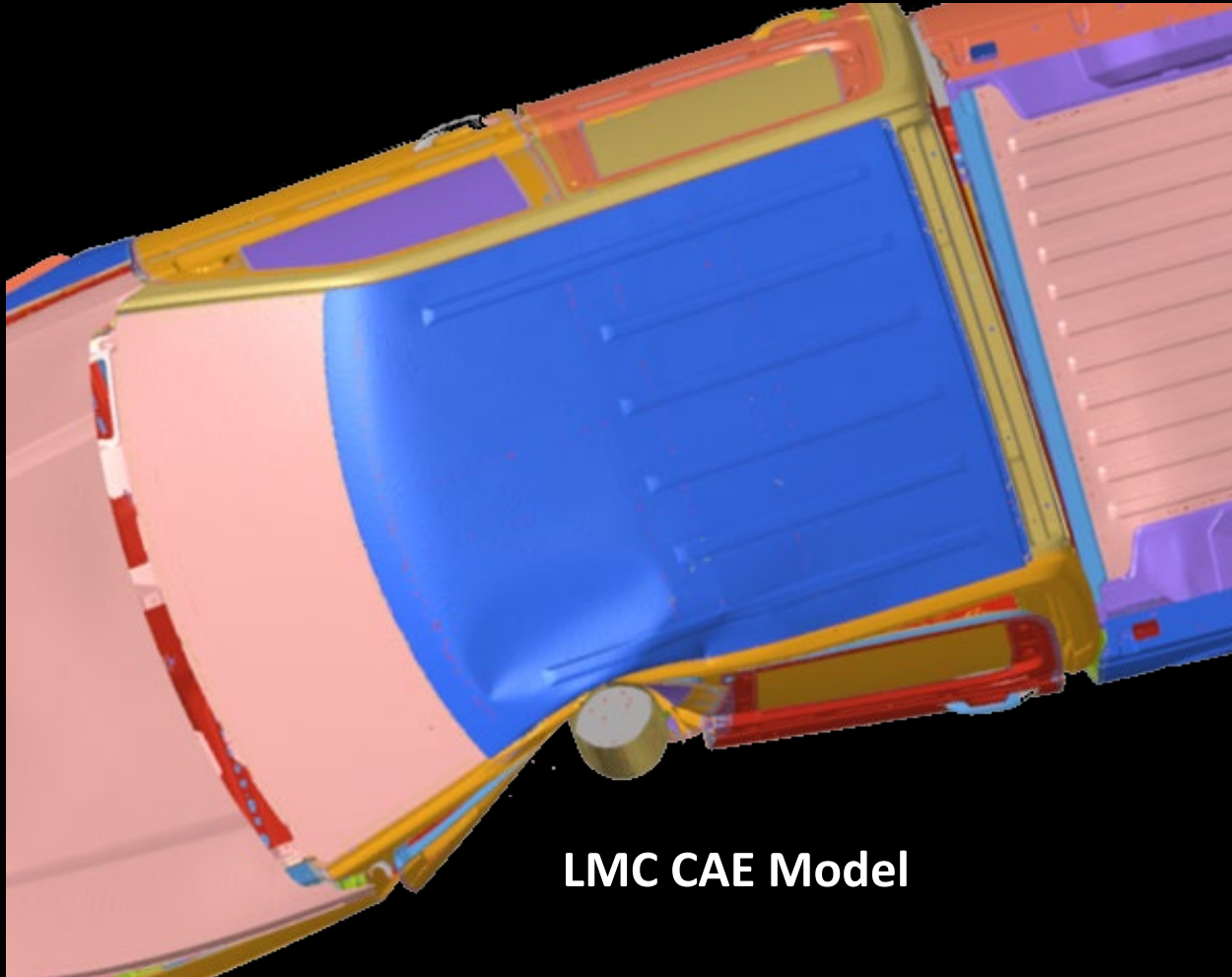

**LMC CAE Model**

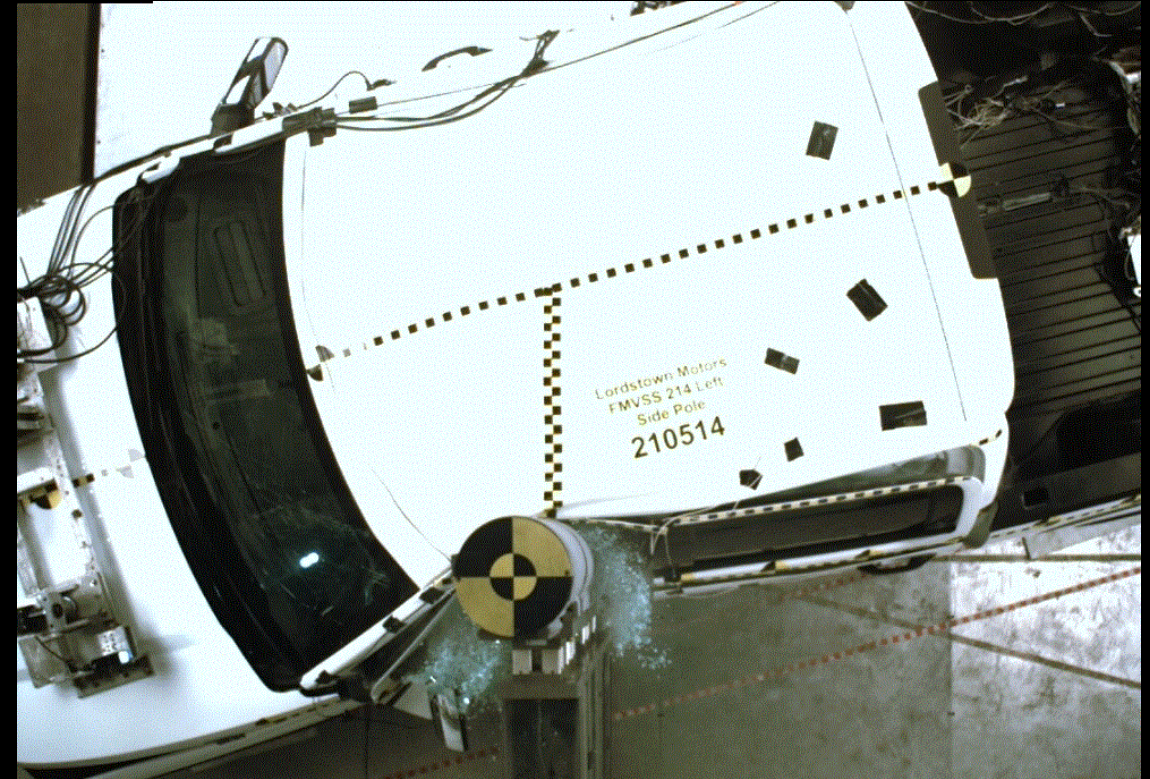

**LMC Beta 8 Test**

# Supply chain is an opportunity across the technology spectrum for EV companies leading the revolution: Industry Needs Supplier & OEM Collaboration and Partnerships.

